

東莞永力電業有限公司

YUNG LI CO., LTD

Da Pu Industrial Zone, Gang Zi, Changping Town,
Dong Guan City, Guangdong 523571 China.P.R.C

TEL:0769-83396797~8

FAX:0769-83396796

E-mail: sales@yung-li.com

Description: YP-12/YC-14

Customer: MAG

Parts No. : CB-3-US

Draw No. :

REVISION RECORD

1		
2		
3		
4		
5		

YUNG LI	
CHECKED	PREPARED BY

CUSTOMER	APPROVED

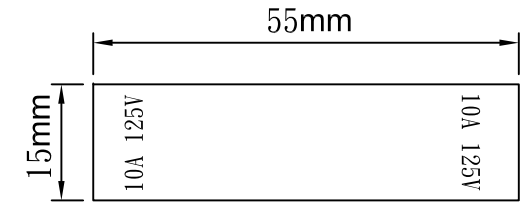
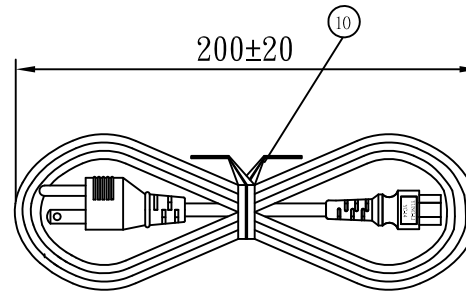
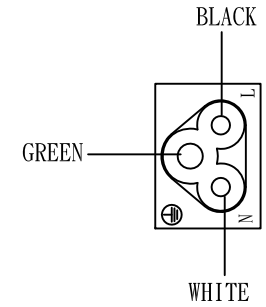
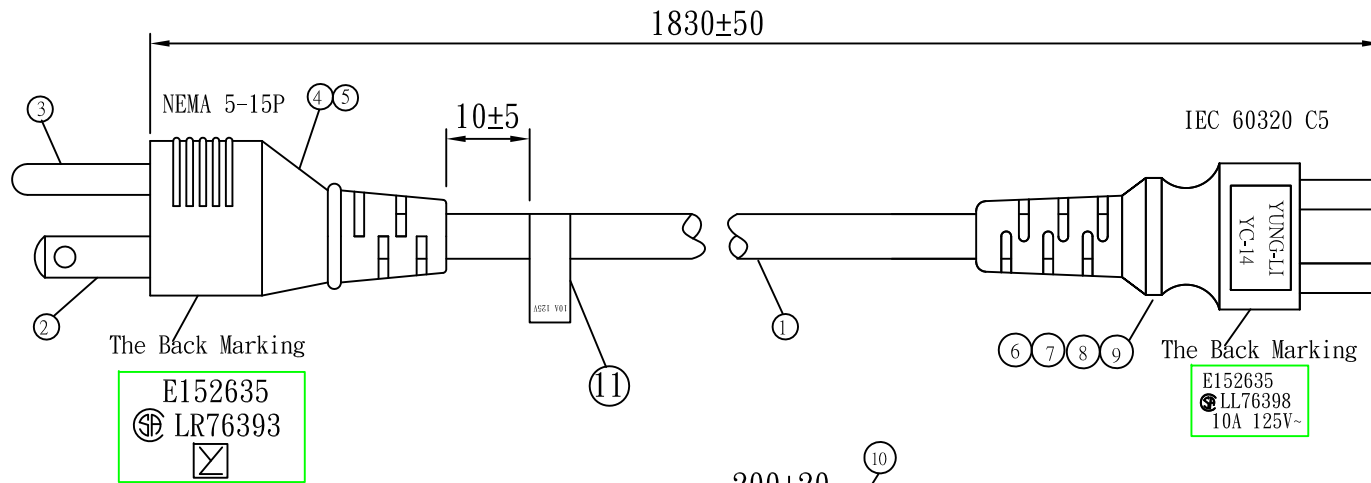
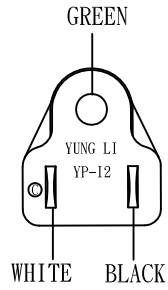

NO.	SPECIFICATION	Q' TY	REMARK
1	SVT 18/3C 105°C BLACK	1PC	
2	TER: 98675BS-1	2PCS	
3	TER:98475	1PC	
4	YP-12 INNER BODY	1PC	
5	YP-12 PVC PLASTIC:35P BLACK	19g/PC	
6	YC-14 PVC PLASTIC:35P BLACK	18g/PC	
7	TER:98732PS-0	1PC	
8	TER:98714PS-0	2PCS	
9	YC-14 H. S. G	1PC	
10	MINI TIE:L=130mm BLACK	1PC	
11	LABEL:55*15mm	1PC	

Tolerance >0±0.30 >1.0±0.50 >10.0±1.0 >20.0±2.0 Angle: ±1°	Approved		Date		YUNG LI CO.,LTD			
	Checked		Date					
	Drawn	SUKI	Date	12.12.05	Customer	MAG		
	Cat. No.	YP-12/YC-14			P/N.	CB-3-US		
	Drawing No.	CY-U0089	Rev.	B	Material	P. V. C	Unit	mm

YUNG LI CO.,LTD

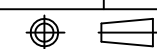

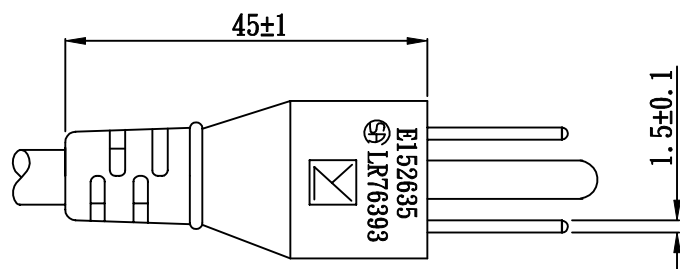
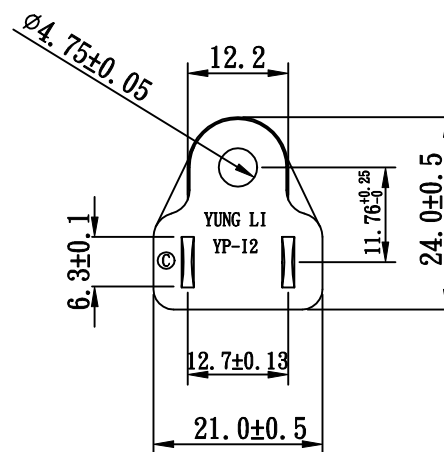
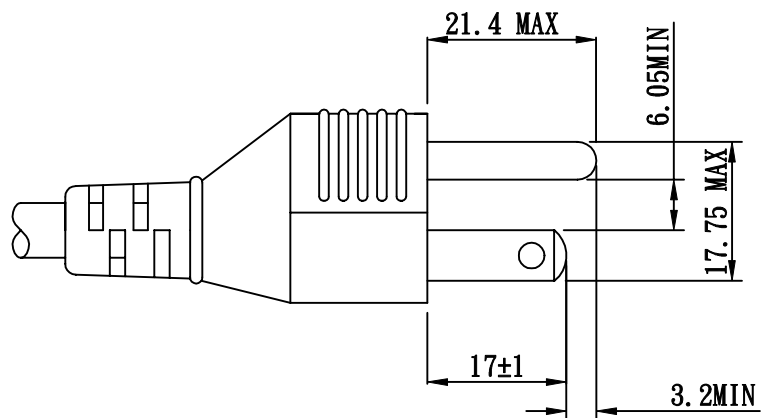

TOLERANCE >0±0.30 >1.0±0.50 >10.0±1.0 >20.0±2.0 Angle: ±1°	APPROVED		DATE		YUNG LI CO., LTD			
	CHECKED		DATE					
	DRAWN		DATE		CUSTOMER			
	TYPE	YP-12			P/N			
	P/N				MATERIAL	P. V. C	UNIT	mm
	DRAWING NO.	CY-P12U	REV	B	SCALE	1:1		

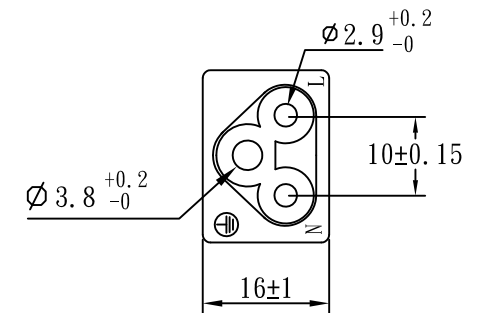
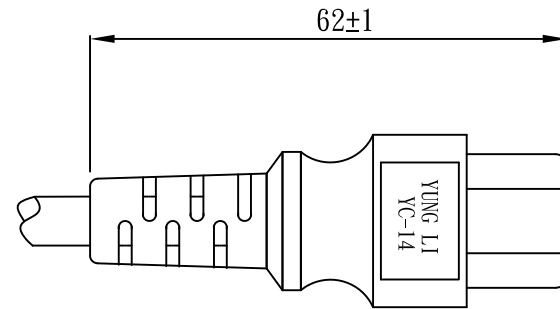
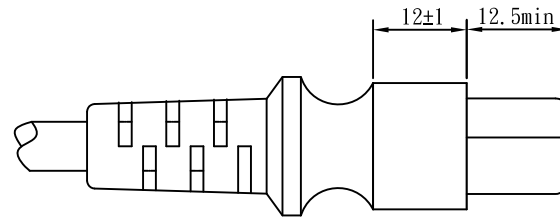
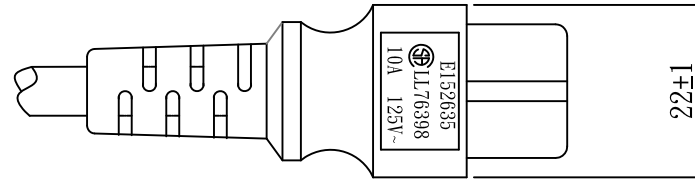
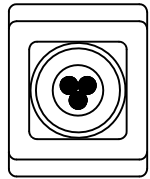

TOLERANCE >0±0.30 >1.0±0.50 >10.0±1.0 >20.0±2.0 Angle: ±1°	APPROVED		DATE		YUNG LI CO., LTD			
	CHECKED		DATE					
	DRAWN		DATE		CUSTOMER			
	TYPE	YC-14			P/N			
	DRAWING NO.		REV	B	MATERIAL	P. V. C	UNIT	mm
				SCALE	1:1			

YUNG LI CO., LTD

SPECIFICATION

Yung-Li	Style	PVC FLEXIBLE CORDS	Document No
2007.5.03			
Edition	Size	SVT 18/ 3C 105°C	Page
A			1/2

1. Standard : UL 62 UL 1581

2. Construction & Dimension

	Item	Specification
Conductor	Size	18AWG x 3C
	Material	Annealed Bare Copper
	Construction	41/ ϕ 0.16±0.002
Insulation	Material	P.V.C.
	Minimum Average Thickness	0.38mm
	Minimum Thickness at any point	0.33mm
	Diameter	2.1 ± 0.1
	Identification	Black, Green, White
Core Assembly	Core Twist	3-Core
	Filler	Cotton 6000D
	Assembly Pair	NA
Taping	Mylar Foil	NA
Shielded	A1-Mylar Foil	NA
Drain Wire	Material	NA
	Construction	NA
Jacket	Material	PVC
	Minimum Average Thickness	0.76mm
	Minimum Thickness at any point	0.61mm
	Overall Diameter(Approx)	6.3 ± 0.15
	Color	Any Color

Marking :

YUNG LI (UL) E241374 SVT 3/C 18AWG(0.824mm²) 105°C 300V VW-1
 CSA 177323 SVT 3/C 18AWG(0.824mm²) 105°C 300V FT2

YUNG LI CO., LTD

SPECIFICATION

Yung-Li	Style	PVC FLEXIBLE CORDS	Document No
2007.5.03			
Edition	Size	SVT 18/ 3C 105°C	Page
A			2/2

3. Electrical & Physical Properties			
Item		Specification	
Rating Voltage		300V	
Insulation Resistance		$\geq 0.76\text{M}\Omega/\text{Km}$ 15.0°C Min	
Dielectric Strength		AC 1.5KV/1 min No Crack	
Resistance of cond.		21.8 Ω .Km (20°C)	
Spark Test		3.0KV/0.15 Sec	
Insulation	Unaged	Tensile Strength	1500 lbs/in2 min
		Elongation	100% Min
	Aged	Tensile Strength	Min 85% (136±1°C x 168hrs)
		Elongation	Min 65% (136±1°C x 168hrs)
Jacket	Unaged	Tensile Strength	1500 lbs/in2 min
		Elongation	100% Min
	Aged	Tensile Strength	Min 85% (136±1°C x 168hrs)
		Elongation	Min 45% (136±1°C x 168hrs)
Deformation Test		121°C±1°C m X 1hr $\leq 50\%$	
Cold Bend Test		-20°C x 4hr No Crack	
Heat Shock Test		121°C±1°C x 1hr No Crack	
Flame Test		VW-1	

Graph:

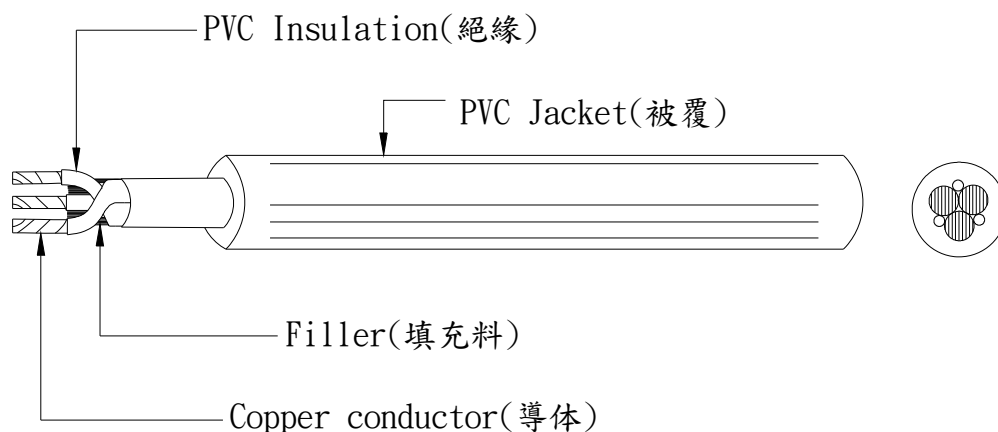



ELBZ7.E152635

Cord Sets and Power-supply Cords Certified for Canada

Page Bottom

Cord Sets and Power-supply Cords Certified for Canada

[See General Information for Cord Sets and Power-supply Cords Certified for Canada](#)

YUNG LI CO LTD

E152635

1ST FL

10 LANE 235 PAO-CHIAO RD

HSIN-TIEN, TAIPEI HSIEN 231 TAIWAN

Power-supply cords

Cat. No.	ANSI /NEMA WD6 Config	Cord AWG	Cord Type	Electrical Rating Amps V
YP-11	1-15	18/2	SPT-1, SPT-1W, NISPT-1, SPT-2, SPT-2W, NISPT-2, SPT-3, HPN, SVT, SVTO, SJT, SJTW, SJTO, SJTOW, SV, SVO, SJ, SJO, SJOW, SJOOW	10/125
		17/2	SVT, SVTO, SV, SVO, SJ, SJO, SJOW, SJOOW	12/125
		16/2	SPT-2, SPT-2W, NISPT-2, SPT-3, SVT, SVTO, SJT, SJTW, SJTO, SJTOW, SV, SVO, SJ, SJO, SJOW, SJOOW	13/125
		16/2	HPN	15/125
		14/2	SPT-3, SJT, SJTW, SJTO, SJTOW, SJ, SJO, SJOW, SJOOW	15/125
YP-11W	1-15P	18/2	SPT-1, SPT-1W, NISPT-1, SPT-2, SPT-2W, NISPT-2, SPT-3, HPN, SVT, SVTO, SJT, SJTW, , SJTO, SJTOW, SV, SVO, SJ, SJO, SJOW, SJOOW	10/125
		17/2	SVT, SVTO, SV, SVO, SJ, SJO, SJOW, SJOOW	12/125
		16/2	SPT-2, SPT-2W, NISPT-2, SPT-3, SVT, SVTO, SJT, SJTW, SJTO, SJTOW, SV, SVO, SJ, SJO, SJOW, SJOOW	13/125
		16/2	HPN	15/125
		14/2	SPT-3, SJT, SJTW, SJTO, SJTOW, SJ, SJO, SJOW, SJOOW	15/125
YP-11C	1-15	18/2	NISPT-1, NISPT-2	10/125
YP-12	5-15	18/3	SVT, SVT Shielded, SVTO, SJT, SJT Shielded, SJTW, SJTW Shielded, SJTO, SJTO Shielded, SJTOW, SJTOW Shielded, ST, ST Shielded, STW, STW Shielded, STOW, STOW Shielded, SV, SVO, SJ, SJ Shielded, SJO, SJO Shielded, SJOOW, SJOOW Shielded, S, SO, SO Shielded, SOO, SOO Shielded, SOW, SOW Shielded, SOOW, SOOW Shielded, SPT-2, SPT-3	10/125
		17/3	SVT, SVTO, SV, SVO	12/125
		16/3	SVT, SVT Shielded, SVTO, SJT, SJT Shielded, SJTW, SJTW Shielded, SJTO, SJTO Shielded, SJTOW, SJTOW Shielded, ST, ST Shielded, STW, STW Shielded, STOW, STOW Shielded, SV, SVO, SJ, SJ Shielded, SJO, SJO Shielded, SJOOW, SJOOW Shielded, S, S, SOW, SOW Shielded, SOOW, SOOW Shielded, SPT-2, SPT-3	13/125

14/3	SJT, SJTW, SJTO, SJTOW, SJ, SJO, SJOO, SJOW, SJOOW (Shielded and Non-shielded for all types)	15/250
------	--	--------

Special-use cord sets

Cat. No.	IEC 320 Config	Cord AWG	Cord Type	Electrical Rating Amps V
YC-11	IEC C17	18	SPT-1, SPT-2, NISPT-1, NISPT-2, SPT-3, SVT, SJT, SJTO, SJTOW, ST, STW, STOW, SO, SOW, SOOW	10/125 or 250
		16	SPT-2, NISPT-2, SPT-3, SVT, SJT, SJTW, SJTO, SJTOW, ST, STW, STOW, SO, SOW, SOOW	13/125 or 250
YC-12, YC-12L, YC-12L-1, YC-12L-2, YC-12L-3	IEC C13	18	SVT, SVT Shielded, SJT, SJT Shielded, SJTW, SJTW Shielded, SJTO, SJTO Shielded, SJTOW, SJTOW Shielded, SJ, SJ Shielded, SJO, SJO Shielded, SJOO, SJOO Shielded, SJOW, SJOW Shielded, SJOOW, SJOOW Shielded, ST, ST Shielded, STW, STW Shielded, STOW, STOW Shielded, SO, SO Shielded, SOO, SOO Shielded, SOW, SOW Shielded, SOOW, SOOW Shielded, SPT-2, SPT-3	10/125 or 250
		16	SJT, SJT Shielded, SJTW, SJTW Shielded, SJTO, SJTO Shielded, SJTOW, SJTOW Shielded, ST, ST Shielded, STW, STW Shielded, STOW, STOW Shielded, SJ, SJ Shielded, SJO, SJO Shielded, SJOO, SJOO Shielded, SJOW, SJOW Shielded, SJOOW, SJOOW Shielded, SO, SO Shielded, SOO, SOO Shielded, SOW, SOW Shielded, SOOW, SOOW Shielded, SPT-3	13/125 or 250
		14	SJT, SJT Shielded, SJTW, SJTW Shielded, SJTO, SJTO Shielded, SJTOW, SJTOW Shielded, ST, ST Shielded, STW, STW Shielded, STOW, STOW Shielded, SJ, SJ Shielded, SJO, SJO Shielded, SJOO, SJOO Shielded, SJOW, SJOW Shielded, SJOOW, SJOOW Shielded, SO, SO Shielded, SOO, SOO Shielded, SOW, SOW Shielded, SOOW, SOOW Shielded, SPT-3	15/125 or 250
		12	SJT, SJT Shielded, SJTW, SJTW Shielded, SJTO, SJTO Shielded, SJTOW, SJTOW Shielded, ST, ST Shielded, STW, STW Shielded, STOW, STOW Shielded, SJ, SJ Shielded, SJO, SJO Shielded, SJOO, SJOO Shielded, SJOW, SJOW Shielded, SJOOW, SJOOW Shielded, SO, SO Shielded, SOO, SOO Shielded, SOW, SOW Shielded, SOOW, SOOW Shielded	15/125 or 250
YC-12 (A.C.1)	IEC C13	12	SJT, SJTW, SJTO, SJTOW, ST, STW, STOW, SO, SOW, SOOW, SPT-3	125/250
		10	SJT, SJTW, SJTO, SJTOW, ST, STW, STOW, SO, SOW, SOOW	125/250
YC-12C	IEC C13	18	NISPT-2	125/250
		16	NISPT-2	125/250
YC-13	IEC C7	18	SPT-1, SPT-1W, SPT-2, SPT-2W, NISPT-2, SVT, SJT	2.5/250 or 10/125
			NISPT-1	
YC-13W	IEC C7P	18	SPT-1, SPT-1W, SPT-2, SPT-2W, NISPT-2	2.5/250 or 10/125
YC-14	IEC C5	18	SVT, SVT Shielded, SVTO, SJT, SJT Shielded, SJTW, SJTW Shielded, SJTO, SJTOW, SV, SVO, SJ, SJO, SJOW, SJOOW	2.5/250 or 7/125 or 10/125 or 250
			SPT-2	
YC-13L	IEC C7	18	SPT-1, SPT-1W, SPT-2, SPT-2W	2.5/250 or 10/125
YC-13D	IEC C7	18	SPT-1, SPT-1W, SPT-2, SPT-2W, NISPT-1, NISPT-2, SJT, SVT	2.5/250 or 10/125
YC-13C	IEC C7	18	NISPT-1, NISPT-2	2.5/250 or 10/125
YC-14L, YC-	IEC C5	18	SVT, SJT, SPT-2	2.5/250 or



CERTIFICATION RECORD

The company named below has been authorized by CSA to represent the products listed in this record as "CSA Certified" and to affix the CSA Mark to these products according to the terms and conditions of the CSA Service Agreement and applicable CSA program requirements (including additional Markings).

File No: 076393 0 000

Class No: 5842 02 CORD SETS Power Supply Cords

SUBMITTOR

4554507 Yung Li Company Ltd.
1F No 10 Lane 235 Pao Chiao Rd
Hsin Tien City
Taipei Hsien,
Taiwan

FACTORY

4554507 Yung Li Company Ltd.
1F No 10 Lane 235 Pao Chiao Rd
Hsin Tien City
Taipei Hsien,
Taiwan

October 11, 2001(Replaces:April 23, 2001)

IN COMPLIANCE WITH CSA STD. C22.2 NO 21-95:

- Power supply cords consisting of the following plug caps moulded on flexible cords as indicated:

Cat No Plug Caps	Config- uration	Rating of PSC			Flexible Cord
		Amp	Volts	AWG	Type
YP-11, -11W	1-15P	10	125	18	SPT-1,-2, SVT, SPT-2 non-integral SPT-2, SVT, SPT-2 non-integral
		13	125	16	
YP-12, YP-12L	5-15P	10	125	18	SJT,SVT, SVT(Sh), SPT-2 SJT, SPT-2 SJT
		13	125	16/3	
		15	125	14/3	
YP-12A	5-15P	15	125	14/3	ST
YP-32	2p, 3W(Sp) (Sd)	10	125	18	SJT, SVT, SVT(Sh)



The company named below has been authorized by CSA to represent the products listed in this record as "CSA Certified" and to affix the CSA Mark to these products according to the terms and conditions of the CSA Service Agreement and applicable CSA program requirements (including additional Markings).

File No: 076398 0 000

Class No: 5841 03 CORD SETS Special-use Cord Sets

SUBMITTOR

Yung Li Company Ltd.
4554507 1F No 10 Lane 235 Pao Chiao Rd
Hsin Tien City
Taipei Hsien,
Taiwan

FACTORY

Yung Li Company Ltd.
4554507 1F No 10 Lane 235 Pao Chiao Rd
Hsin Tien City
Taipei Hsien,
Taiwan

June 18, 2002(Replaces:June 7, 2002)

TO THE REQUIREMENTS OF CSA STD C22.2 NO. 21-95:

- Special-use cord sets consisting of the following connector bodies moulded onto any of the submittor's Certified power supply cords indicated:

Power Supply Cord

Connector Body		Plug Cap		Flexible Cord	
Cat No.	Rating	Cat No	Config	AWG	Type
YC-12(Sp23)	10A, 125V	YP-12	5-15P	18	SJT, SVT, SVT (Sh), SPT-2
	13A, 125V	YP-12	5-15P	16	SJT
	15A, 125V	YP-12	5-15P	14	SJT
	10A, 125V	YP-32 (Sd)	(SP23)	18	SJT, SVT, SVT (Sh)
YC-14(SP23)	10A, 125V	YP-12	5-15P	18	SJT, SVT, SPT-2

LEGEND: "(Sp23)" Special use, 2-pole, 3 wire grounding type; "(Sd)" Shrouded; "(Sh)" Shielded.

**ZJCZ.E241374**
Flexible Cord[Page Bottom](#)

Flexible Cord[See General Information for Flexible Cord](#)**YUNG LI CO LTD**

E241374

1ST FL

10 LANE 235 PAO-CHIAO RD

HSIN-TIEN, TAIPEI HSIEN 231 TAIWAN

Jacketed cords, Type SJTW, STW, SJTO, SJTOW, STO, STOW, SJ, S, SJO, SO, SVT, SVTO, SJT, ST, SJOW, SJOOW, SOW, SOOW, SJOO, SOO.

Parallel cords, Type SPT-1, SPT-2, SPT-3, SPT-1W, SPT-2W, NISPT-1, NISPT-2.

Rang and dryer cord, Type SRDT.

[Last Updated on 2007-02-12](#)

[Questions?](#)[Notice of Disclaimer](#)[Page Top](#)[Copyright © 2007 Underwriters Laboratories Inc.®](#)

The appearance of a company's name or product in this database does not in itself assure that products so identified have been manufactured under UL's Follow-Up Service. Only those products bearing the UL Mark should be considered to be Listed and covered under UL's Follow-Up Service. Always look for the Mark on the product.

UL permits the reproduction of the material contained in the Online Certification Directory subject to the following conditions: 1. The Guide Information, Designs and/or Listings (files) must be presented in their entirety and in a non-misleading manner, without any manipulation of the data (or drawings). 2. The statement "Reprinted from the Online Certifications Directory with permission from Underwriters Laboratories Inc." must appear adjacent to the extracted material. In addition, the reprinted material must include a copyright notice in the following format: "Copyright © 2007 Underwriters Laboratories Inc.®"

An independent organization working for a safer world with integrity, precision and knowledge.



Certificate of Compliance

Certificate: 1594794 (LL 76398)

Master Contract: 177323

Project: 2128031

Date Issued: 2009/03/03

Issued to: Yung Li Company Ltd.
1F No 10 Lane 235 Pao Chiao Rd
Hsin Tien City
Taipei Hsien,
Taiwan
Attention: Mr. W.T. Lai

The products listed below are eligible to bear the CSA Mark shown



Issued by: Kim Nguyen, P. Eng.



Authorized by: Nick Alfano, Operations
Manager



PRODUCTS

CLASS 5831 01 - WIRES - Flexible Cord

Types SPT-1, NISPT-1, SPT-2, NISPT-2, SPT-3, SVT, SVTO, SJT, SJTW, SJTO, SJTOW, ST, STW, STO, STOW with PVC insulation and jacket, rated 60C, 75C, 90C and 105C, FT1, FT2, VW-1.

APPLICABLE REQUIREMENTS

CSA C22.2 No 49 - Flexible Cords and Cables



Supplement to Certificate of Compliance

Certificate: 1594794

Master Contract: 177323

The products listed, including the latest revision described below, are eligible to be marked in accordance with the referenced Certificate.

Product Certification History

Project	Date	Description
2128031	2009/03/03	Adding temperature ratings of 75C and 90C to Types SPT-1,-2,-3, NISPT-1,-2, SVT, SJT, SJTW, ST and STW.
1929621	2007/10/17	Types SJTO, SJTOW, STO, STOW, SVTO added.
1625068	2005/01/10	Addition of Flexible cords Types SJTW, STW rated 60C, 105C
1594794	2004/10/14	Original Certification: Flexible Cords SPT-1, -2, -3, NISPT-1, -2, SVT, SJT, ST

Test Report

Report No.: RLSZE0011899301

Page 1 of 16

Applicant : YUNG LI CO.,LTD

Address : DA PU INDUSTRIAL ZONE,GANG ZI,CHANG PING TOWN, DONG GUAN CITY,GUANG DONG 523571 CHINA

Report on the submitted sample(s) said to be:

No.	Sample Names	Sample Description
1	PVC BLACK	Black plastic grains
2	PVC WHITE	White plastic grains
3	PVC BROWN	Brown plastic grains
4	PVC BLUE	Blue plastic grains
5	PVC YELLOW	Yellow plastic grains
6	PVC GREEN	Green plastic grains
7	PVC RED	Red plastic grains
8	INK	White liquid
9	CABLE COPPER	Cupreous metal
10	INNERBODY	White plastic
11	TERMINAL COPPER	Golden color metal

Part No. : Please refer to the page 13-14.

Sample Received Date : Mar. 2, 2012

Testing Period : Mar. 2, 2012 to Mar. 8, 2012

Test Requested : As specified by client, to test Lead(Pb), Cadmium(Cd), Mercury(Hg), Hexavalent Chromium(Cr(VI)), Polybrominated Biphenyls(PBBs), Polybrominated Diphenyl Ethers(PBDEs), Polycyclic Aromatic Hydrocarbons(PAHs), Perfluorooctane Sulfonates(PFOS), Tetrabromobisphenol-A (TBBP-A) in the submitted sample(s).

Test Method: Please refer to the following page(s).

Test Result(s): Please refer to the following page(s).

Tested by

Rick
Dingli

Approved by

Technical Manager



Inspected by

Vargas

Date

Mar. 8, 2012

No. 38475376

Test Report

Report No.: RLSZE0011899301

Page 2 of 16

Test Method:

Tested Item(s)	Test Method	Measured Equipment(s)	MDL
Lead (Pb)	IEC 62321:2008 Ed.1 Sec.8	ICP-OES	2 mg/kg
	IEC 62321:2008 Ed.1 Sec.9		
	IEC 62321:2008 Ed.1 Sec.10		
Cadmium (Cd)	IEC 62321:2008 Ed.1 Sec.8	ICP-OES	2 mg/kg
	IEC 62321:2008 Ed.1 Sec.9		
	IEC 62321:2008 Ed.1 Sec.10		
Mercury (Hg)	IEC 62321:2008 Ed.1 Sec.7	ICP-OES	2 mg/kg
Hexavalent Chromium (Cr(VI))	IEC 62321:2008 Ed.1 Annex B	UV-Vis	/
	IEC 62321:2008 Ed.1 Annex C		2 mg/kg
Polybrominated Biphenyls (PBBs)	IEC 62321:2008 Ed.1 Annex A	GC-MS	5 mg/kg
Polybrominated Diphenyl Ethers (PBDEs)	IEC 62321:2008 Ed.1 Annex A	GC-MS	5 mg/kg
Perfluorooctane Sulfonates (PFOS)	Refer to US EPA 3550C:2007	LC-MS-MS	5 mg/kg
Tetrabromobisphenol-A (TBBP-A)	Refer to US EPA 3540C:1996	GC-MS	5 mg/kg
Polycyclic Aromatic Hydrocarbons (PAHs)	Refer to US EPA 3550C:2007 & US EPA 8270D:2007	GC-MS	0.2 mg/kg

Test Report

Report No.: RLSZE0011899301

Page 3 of 16

Test Result(s):

Tested Item(s)	Content		
	Sample No.1	Sample No.2	Sample No.3
Lead (Pb)	N.D.	N.D.	N.D.
Cadmium (Cd)	N.D.	N.D.	N.D.
Mercury (Hg)	N.D.	N.D.	N.D.
Hexavalent Chromium (Cr(VI))	N.D.	N.D.	N.D.
Perfluorooctane Sulfonates (PFOS)	N.D.	N.D.	N.D.
Tetrabromobisphenol-A (TBBP-A)	N.D.	N.D.	N.D.

Tested Item(s)	Content			
	Sample No.4	Sample No.5	Sample No.6	Sample No.7
Lead (Pb)	N.D.	N.D.	N.D.	N.D.
Cadmium (Cd)	N.D.	N.D.	N.D.	N.D.
Mercury (Hg)	N.D.	N.D.	N.D.	N.D.
Hexavalent Chromium (Cr(VI))	N.D.	N.D.	N.D.	N.D.
Perfluorooctane Sulfonates (PFOS)	N.D.	N.D.	N.D.	N.D.
Tetrabromobisphenol-A (TBBP-A)	N.D.	N.D.	N.D.	N.D.

Tested Item(s)	Content			
	Sample No.8	Sample No.9	Sample No.10	Sample No.11
Lead (Pb)	N.D.	N.D.	9mg/kg	40 mg/kg
Cadmium (Cd)	N.D.	N.D.	N.D.	N.D.
Mercury (Hg)	N.D.	N.D.	N.D.	N.D.
Hexavalent Chromium (Cr(VI))	N.D.	/	N.D.	/
Perfluorooctane Sulfonates (PFOS)	N.D.	/	N.D.	/
Tetrabromobisphenol-A (TBBP-A)	N.D.	/	N.D.	/

Tested Item(s)	Conclusion	
	Sample No.9	Sample No.11
Hexavalent Chromium (Cr(VI))	Negative	Negative

Test Report

Report No.: RLSZE0011899301

Page 4 of 16

Test Result(s):

Tested Item(s)	Content		
	Sample No.1	Sample No.2	Sample No.3
Polybrominated Biphenyls(PBBs)			
Monobromobiphenyl	N.D.	N.D.	N.D.
Dibromobiphenyl	N.D.	N.D.	N.D.
Tribromobiphenyl	N.D.	N.D.	N.D.
Tetrabromobiphenyl	N.D.	N.D.	N.D.
Pentabromobiphenyl	N.D.	N.D.	N.D.
Hexabromobiphenyl	N.D.	N.D.	N.D.
Heptabromobiphenyl	N.D.	N.D.	N.D.
Octabromobiphenyl	N.D.	N.D.	N.D.
Nonabromobiphenyl	N.D.	N.D.	N.D.
Decabromobiphenyl	N.D.	N.D.	N.D.
Polybrominated Diphenyl Ethers(PBDEs)			
Monobromodiphenyl ether	N.D.	N.D.	N.D.
Dibromodiphenyl ether	N.D.	N.D.	N.D.
Tribromodiphenyl ether	N.D.	N.D.	N.D.
Tetrabromodiphenyl ether	N.D.	N.D.	N.D.
Pentabromodiphenyl ether	N.D.	N.D.	N.D.
Hexabromodiphenyl ether	N.D.	N.D.	N.D.
Heptabromodiphenyl ether	N.D.	N.D.	N.D.
Octabromodiphenyl ether	N.D.	N.D.	N.D.
Nonabromodiphenyl ether	N.D.	N.D.	N.D.
Decabromodiphenyl ether	N.D.	N.D.	N.D.

Test Report

Report No.: RLSZE0011899301

Page 5 of 16

Test Result(s):

Tested Item(s)	Content		
	Sample No.4	Sample No.5	Sample No.6
Polybrominated Biphenyls(PBBs)			
Monobromobiphenyl	N.D.	N.D.	N.D.
Dibromobiphenyl	N.D.	N.D.	N.D.
Tribromobiphenyl	N.D.	N.D.	N.D.
Tetrabromobiphenyl	N.D.	N.D.	N.D.
Pentabromobiphenyl	N.D.	N.D.	N.D.
Hexabromobiphenyl	N.D.	N.D.	N.D.
Heptabromobiphenyl	N.D.	N.D.	N.D.
Octabromobiphenyl	N.D.	N.D.	N.D.
Nonabromobiphenyl	N.D.	N.D.	N.D.
Decabromobiphenyl	N.D.	N.D.	N.D.
Polybrominated Diphenyl Ethers(PBDEs)			
Monobromodiphenyl ether	N.D.	N.D.	N.D.
Dibromodiphenyl ether	N.D.	N.D.	N.D.
Tribromodiphenyl ether	N.D.	N.D.	N.D.
Tetrabromodiphenyl ether	N.D.	N.D.	N.D.
Pentabromodiphenyl ether	N.D.	N.D.	N.D.
Hexabromodiphenyl ether	N.D.	N.D.	N.D.
Heptabromodiphenyl ether	N.D.	N.D.	N.D.
Octabromodiphenyl ether	N.D.	N.D.	N.D.
Nonabromodiphenyl ether	N.D.	N.D.	N.D.
Decabromodiphenyl ether	N.D.	N.D.	N.D.

Test Report

Report No.: RLSZE0011899301

Page 6 of 16

Test Result(s):

Tested Item(s)	Content		
	Sample No.7	Sample No.8	Sample No.10
Polybrominated Biphenyls(PBBs)			
Monobromobiphenyl	N.D.	N.D.	N.D.
Dibromobiphenyl	N.D.	N.D.	N.D.
Tribromobiphenyl	N.D.	N.D.	N.D.
Tetrabromobiphenyl	N.D.	N.D.	N.D.
Pentabromobiphenyl	N.D.	N.D.	N.D.
Hexabromobiphenyl	N.D.	N.D.	N.D.
Heptabromobiphenyl	N.D.	N.D.	N.D.
Octabromobiphenyl	N.D.	N.D.	N.D.
Nonabromobiphenyl	N.D.	N.D.	N.D.
Decabromobiphenyl	N.D.	N.D.	N.D.
Polybrominated Diphenyl Ethers(PBDEs)			
Monobromodiphenyl ether	N.D.	N.D.	N.D.
Dibromodiphenyl ether	N.D.	N.D.	N.D.
Tribromodiphenyl ether	N.D.	N.D.	N.D.
Tetrabromodiphenyl ether	N.D.	N.D.	N.D.
Pentabromodiphenyl ether	N.D.	N.D.	N.D.
Hexabromodiphenyl ether	N.D.	N.D.	N.D.
Heptabromodiphenyl ether	N.D.	N.D.	N.D.
Octabromodiphenyl ether	N.D.	N.D.	N.D.
Nonabromodiphenyl ether	N.D.	N.D.	N.D.
Decabromodiphenyl ether	N.D.	N.D.	N.D.

Test Report

Report No.: RLSZE0011899301

Page 7 of 16

Test Result(s):

Tested Item(s)	Content		
	Sample No.1	Sample No.2	Sample No.3
Polycyclic Aromatic Hydrocarbons(PAHs)			
Naphthalene	N.D.	N.D.	N.D.
Acenaphthylene	N.D.	N.D.	N.D.
Acenaphthene	N.D.	N.D.	N.D.
Fluorene	N.D.	N.D.	N.D.
Phenanthrene	N.D.	N.D.	N.D.
Anthracene	N.D.	N.D.	N.D.
Fluoranthene	N.D.	N.D.	N.D.
Pyrene	N.D.	N.D.	N.D.
Benzo[a]anthracene	N.D.	N.D.	N.D.
Chrysene	N.D.	N.D.	N.D.
Benzo[b]fluoranthene	N.D.	N.D.	N.D.
Benzo[k]fluoranthene	N.D.	N.D.	N.D.
Benzo[a]pyrene	N.D.	N.D.	N.D.
Indeno[1,2,3-cd]pyrene	N.D.	N.D.	N.D.
Dibenzo[a,h]anthracene	N.D.	N.D.	N.D.
Benzo[g,h,i]perylene	N.D.	N.D.	N.D.

Test Report

Report No.: RLSZE0011899301

Page 8 of 16

Test Result(s):

Tested Item(s)	Content		
	Sample No.4	Sample No.5	Sample No.6
Polycyclic Aromatic Hydrocarbons(PAHs)			
Naphthalene	N.D.	N.D.	N.D.
Acenaphthylene	N.D.	N.D.	N.D.
Acenaphthene	N.D.	N.D.	N.D.
Fluorene	N.D.	N.D.	N.D.
Phenanthrene	N.D.	N.D.	N.D.
Anthracene	N.D.	N.D.	N.D.
Fluoranthene	N.D.	N.D.	N.D.
Pyrene	N.D.	N.D.	N.D.
Benzo[a]anthracene	N.D.	N.D.	N.D.
Chrysene	N.D.	N.D.	N.D.
Benzo[b]fluoranthene	N.D.	N.D.	N.D.
Benzo[k]fluoranthene	N.D.	N.D.	N.D.
Benzo[a]pyrene	N.D.	N.D.	N.D.
Indeno[1,2,3-cd]pyrene	N.D.	N.D.	N.D.
Dibenzo[a,h]anthracene	N.D.	N.D.	N.D.
Benzo[g,h,i]perylene	N.D.	N.D.	N.D.

Test Report

Report No.: RLSZE0011899301

Page 9 of 16

Test Result(s):

Tested Item(s)	Content		
	Sample No.7	Sample No.8	Sample No.10
Polycyclic Aromatic Hydrocarbons(PAHs)			
Naphthalene	N.D.	3.2 mg/kg	N.D.
Acenaphthylene	N.D.	N.D.	N.D.
Acenaphthene	N.D.	N.D.	N.D.
Fluorene	N.D.	N.D.	N.D.
Phenanthrene	N.D.	N.D.	N.D.
Anthracene	N.D.	N.D.	N.D.
Fluoranthene	N.D.	N.D.	N.D.
Pyrene	N.D.	N.D.	N.D.
Benzo[a]anthracene	N.D.	N.D.	N.D.
Chrysene	N.D.	N.D.	N.D.
Benzo[b]fluoranthene	N.D.	N.D.	N.D.
Benzo[k]fluoranthene	N.D.	N.D.	N.D.
Benzo[a]pyrene	N.D.	N.D.	N.D.
Indeno[1,2,3-cd]pyrene	N.D.	N.D.	N.D.
Dibenzo[a,h]anthracene	N.D.	N.D.	N.D.
Benzo[g,h,i]perylene	N.D.	N.D.	N.D.

Note: The samples had been dissolved totally tested for Lead, Cadmium, Mercury.

-MDL = Method Detection Limit

-N.D. = Not Detected (<MDL)

-mg/kg = ppm = parts per million

-Negative = Absence of Cr(VI), the detected Cr(VI) concentration in the boiling water extraction solution is less than 0.02 mg/kg with 50cm² sample surface area used.

Remark: According to the client's statement, the material of sample No.1, 2, 3, 4, 5, 6, 7, 8, 9 in this report is the same as the sample No. 1, 2, 3, 4, 5, 6, 7, 8, 9 in report No. RLSZE00118993, so the test result(s) are presented in reference to that one.

Test Report

Report No.: RLSZE0011899301

Page 10 of 16

Test Process:

1. Test for Pb/Cd Content

(1) IEC 62321:2008 Ed.1 Sec.8

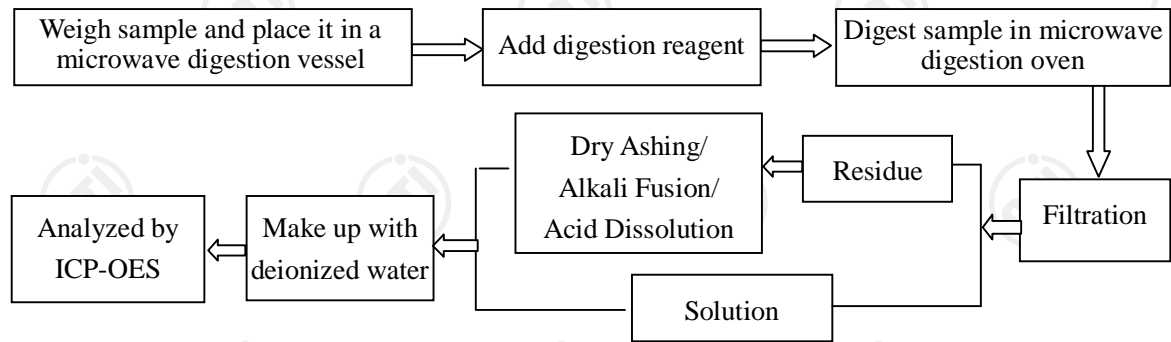

(2) IEC 62321:2008 Ed.1 Sec.9

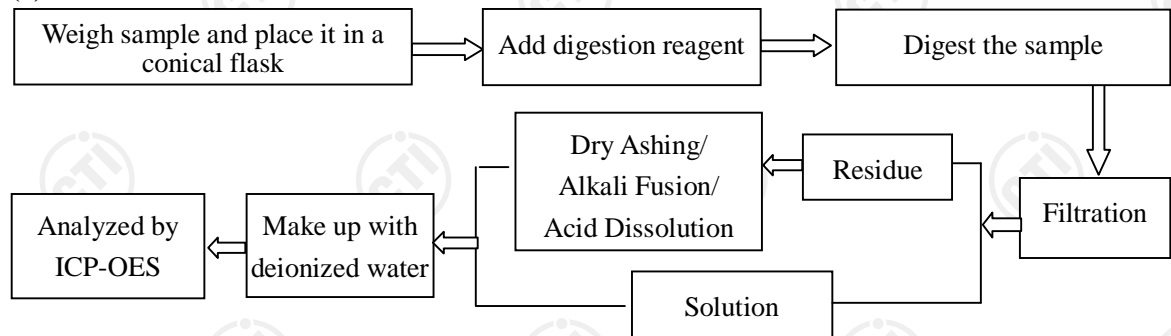

(3) IEC 62321:2008 Ed.1 Sec.10

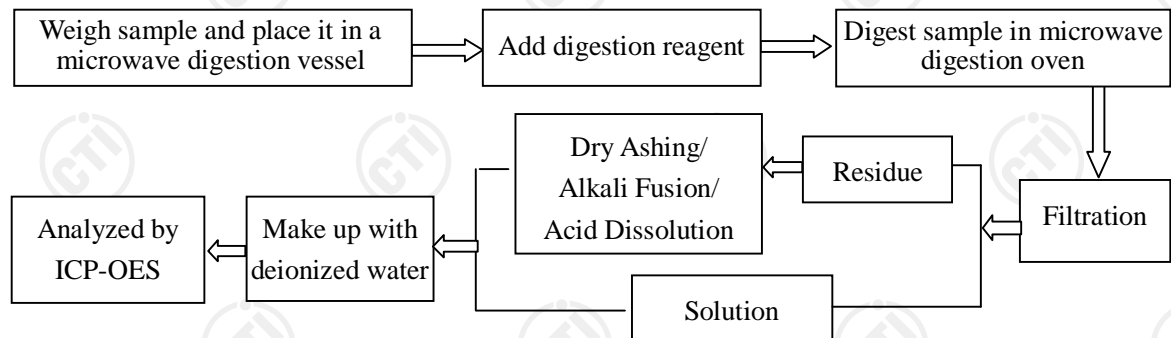

Test Report

Report No.: RLSZE0011899301

Page 11 of 16

2. Test for Hg Content

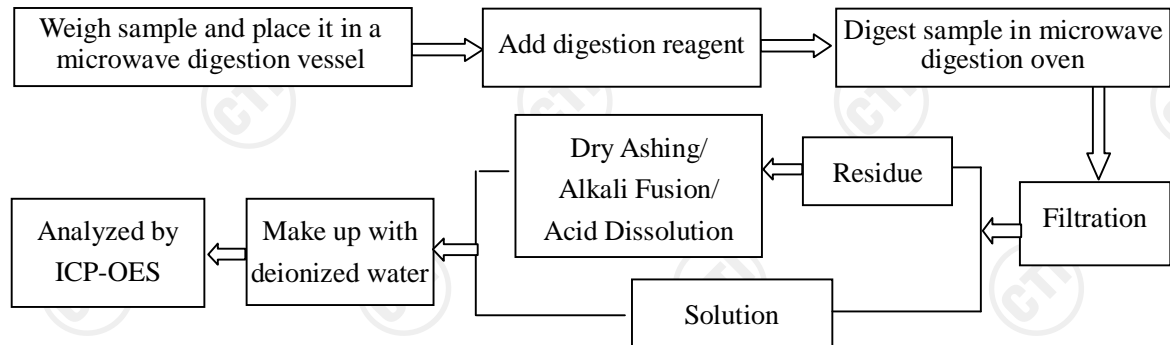

3. Test for Chromium(VI) Content

(1) IEC 62321:2008 Ed.1 Annex B

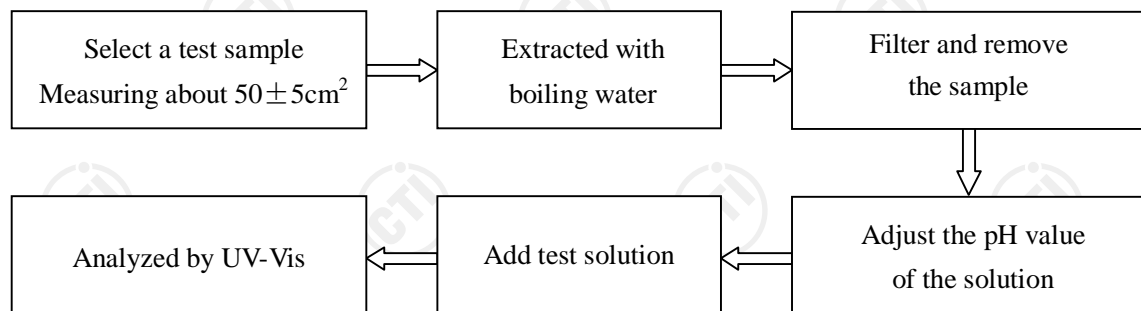

(2) IEC 62321:2008 Ed.1 Annex C

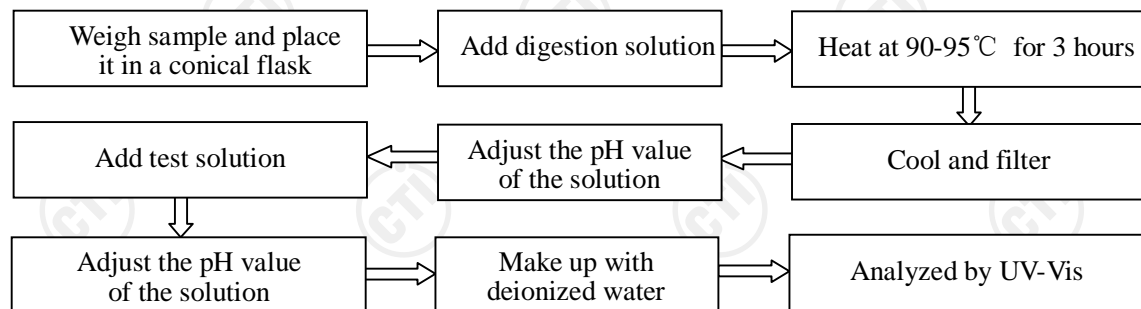

4. Test for PBBs/PBDEs Content

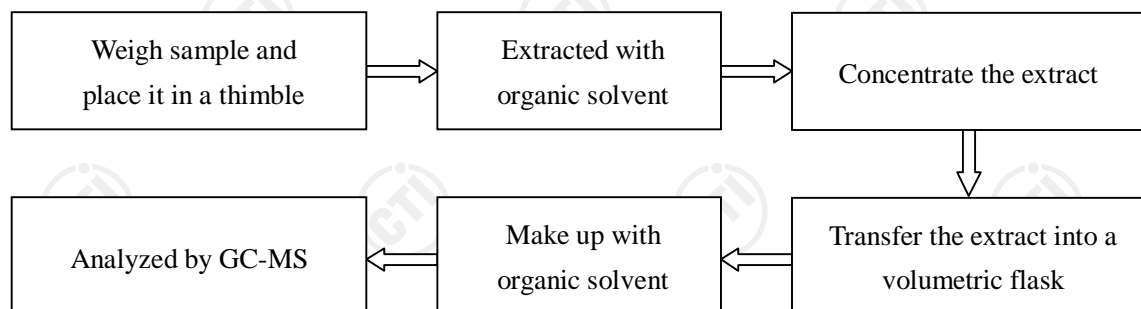

Test Report

Report No.: RLSZE0011899301

Page 12 of 16

5. Test for PFOS Content

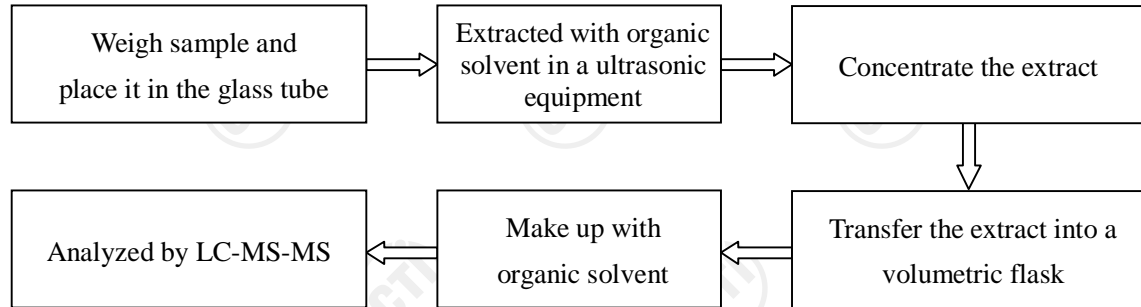

6. Test for TBBP-A Content

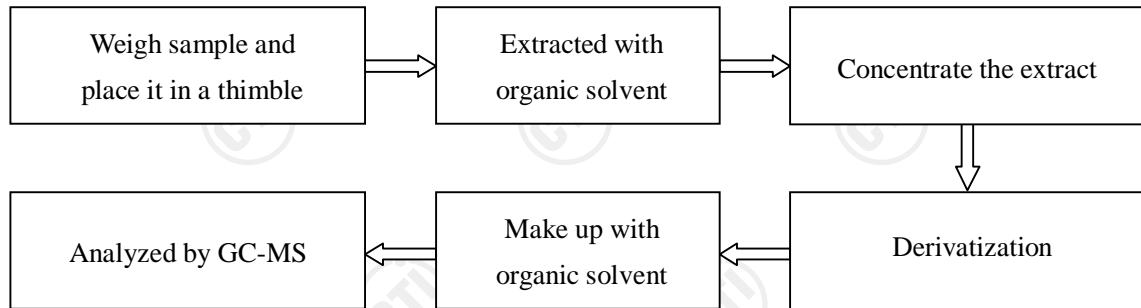

7. Test for PAHs Content

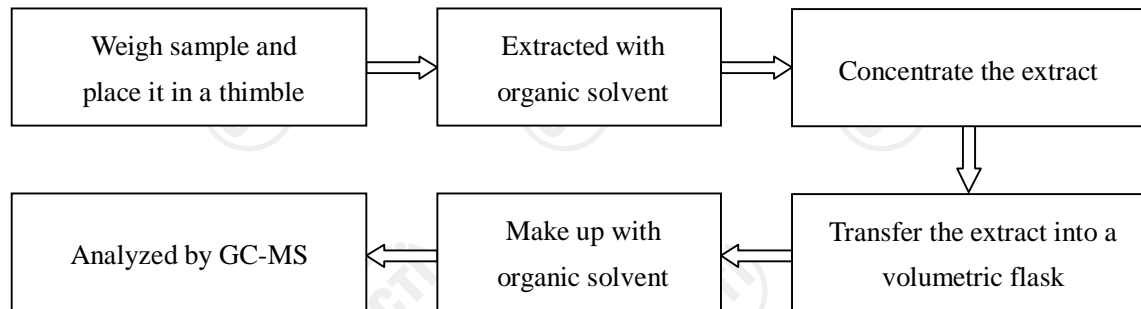

Test Report

Report No.: RLSZE0011899301

Page 13 of 16

Part No.

YP-01	YP-13P	YP-49	YP-33AL	YC-01	YC-14GL	YD-05	YL-0213	YL-3613A
YP-02	YP-13Q	YP-52	YP-32BL	YC-04	YC-14S	YD-06	YL-0222	YL-3613L
YP-02L	YP-13S	YP-53	YP-03A	YC-05	YC-15	YD-07	YL-0312	YL-3621
YP-03	YP-13T	YP-54	YP-03B	YC-05-1	YC-16	YD-09	YL-0314	YL-3621L
YP-03L	YP-13U	YP-55	YP-33AL	YC-05A	YC-17	YD-10	YL-0315	YL-3622
YP-06	YP-13Y	YP-56	YP-33BL	YC-06	YC-18	YD-11	YL-0323	YL-3622L
YP-07	YP-13F	YP-57	YP-316	YC-07W	YC-18L	YD-12	YL-1113	YL-915
YP-08	YP-15	YP-58	YP-332	YC-08	YC-18A	YD-13	YL-1113A	YL-915A
YP-09	YP-15G	YP-58N	YP-516	YC-09	YC-19	YD-14	YL-1113L	YL-916
YP-10	YP-16	YP-59	YP-532	YC-10	YC-20	YD-15	YL-1113B	YL-921
YP-11	YP-16L	YP-62		YC-11	YC-20L	YD-16	YL-1113C	YL-921A
YP-11A	YP-17	YP-63		YC-12	YC-20LR	YD-17	YL-1113BL	YL-921B
YP-11C	YP-17L	YP-64		YC-12A	YC-21	YD-17A	YL-1122	YL-935
YP-11L	YP-18	YP-65		YC-12C	YC-21A	YD-17B	YL-1122L	YL-939
YP-11W	YP-18A	YP-66		YC-12D	YC-22	YD-17L	YL-1200	YL-1800
YP-11P	YP-18B	YP-67		YC-12G	YC-23	YD-18	YL-1212L	YL-27B17
YP-11R	YP-18L	YP-68L		YC-12K	YC-24	YD-19	YL-1214	YL-3215A
YP-11T	YP-18N	YP-69L		YC-12L	YC-25	YD-20	YL-1214L	YL-1255
YP-12	YP-18T	YP-72L		YC-12T	YC-25L	YD-21	YL-1214G	YL-1256
YP-12A	YP-19	YP-73L		YC-12-01	YC-35	YD-22	YL-1214W	YL-1255
YP-12C	YP-19L	YP-74L		YC-12GL	YC-45	YD-23	YL-1223	YL-1653
YP-12E	YP-27	YP-75L		YC-13	YC-46	YD-24	YL-1245	YL-1756
YP-12G	YP-28	YP-76		YC-13A	YC-52	YD-25	YL-1246	YL-1217
YP-12L	YP-29	YP-77		YC-13B	YC-53	YD-26	YL-150	YL-5556

Test Report

Report No.: RLSZE0011899301

Page 14 of 16

Part No.

YP-12N	YP-32	YP-78	YC-13BL	YC-54	YD-27	YL-150A	YL-5655
YP-12P	YP-32L	YP-79	YC-13C	YC-55	YD-28	YL-212	YL-5216
YP-13	YP-32A	YP-82	YC-13D	YC-56	YD-29	YL-312	YL-5316
YP-13B	YP-33	YP-83	YC-13E	YC-58	YD-30	YL-315	YL-5517
YP-13BL	YP-33A	YP-84	YC-13G	YC-59	SR 系列	YL-3213	YL-5617
YP-13C	YP-35	YP-90L	YC-13H	YC-72	YCM-001	YL-3214	YL-321212
YP-13D	YP-36	YP-91L	YC-13K	YC-73	YCM-002	YL-3215	YL-321515
YP-13H	YP-37	YP-92L	YC-13L	YC-77	YCM-003	YL-3223	YL-3320
YP-13HB	YP-39	YP-93L	YC-13LG	YC-79	YCM-004	YL-3512	YL-331212
YP-13HP	YP-40	YP-94L	YC-13S	YC-18K	YCM-005	YL-3512L	YP-3213A
YP-13L	YP-41	YP-95L	YC-13W	YC-17		YL-3514	
YP-13M	YP-42	YP-96L	YC-13F	YC-06R		YL-3515	
YP-13N	YP-43	YP-97L	YC-14	YC-62		YL-3522	
YP-13O	YP-33B	YP-98L	YC-14G	YC-64		YL-3523	
	YP-32A	YP-99L	YC-14L			YL-3613	

Test Report

Report No.: RLSZE0011899301

Page 15 of 16

Photo(s) of the sample(s)

Sample No.1



Sample No.2



Sample No.3



Sample No.4



Sample No.5



Sample No.6



Test Report

Report No.: RLSZE0011899301

Page 16 of 16

Photo(s) of the sample(s)

Sample No.7



Sample No.8



Sample No.9



Sample No.10

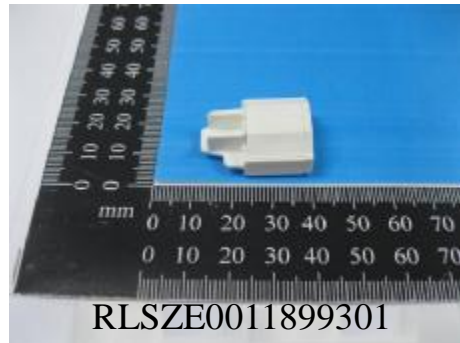

Sample No.11

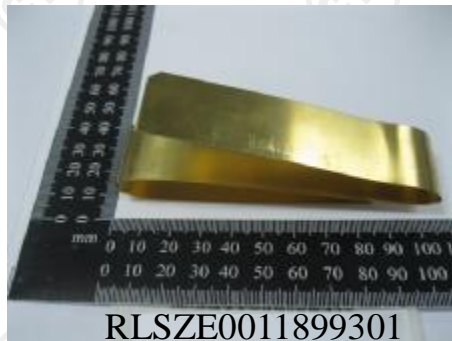

*** End of report ***

This report is considered invalidated without the Special Seal for Inspection of the CTI, This report shall not be altered, increased or deleted. The results shown in this test report refer only to the sample(s) tested. Without written approval of CTI, this test report shall not be copied except in full and published as advertisement.

Building C, Hongwei Industrial Zone, Baoan 70 District, Shenzhen