

CUSTOMER NO:	REMARK
USB-II-2V	MAG

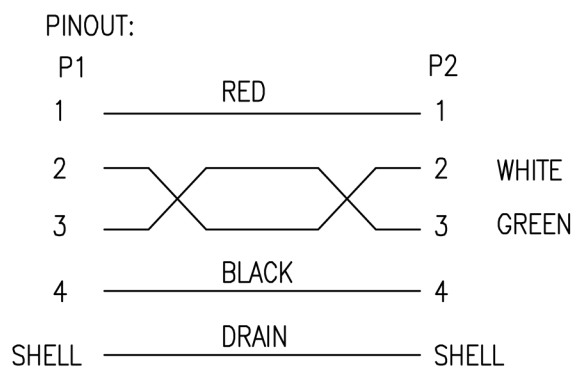
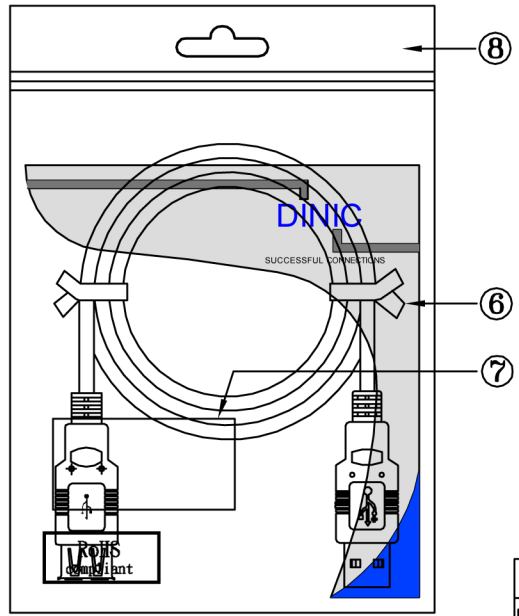
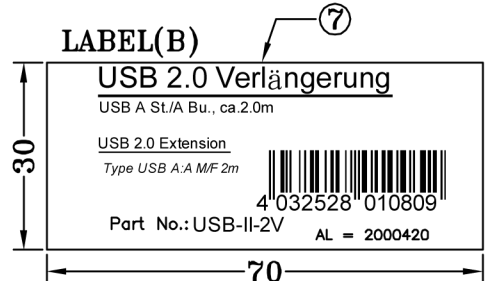
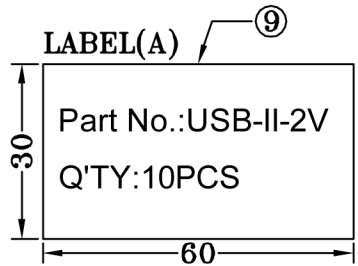
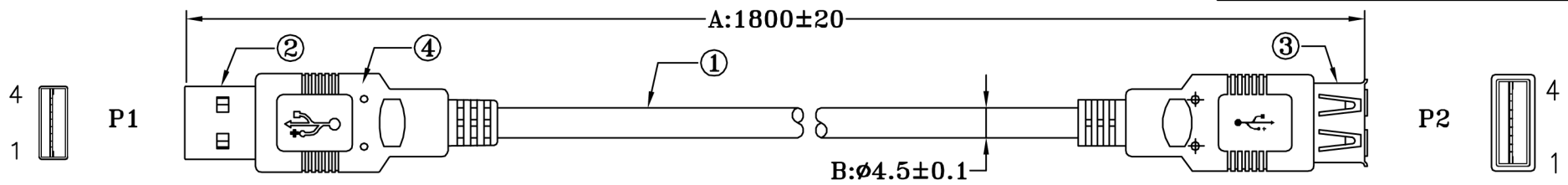

- NOTES:
- 1) P1 DIE NO:OU04012
 - 2) P2 DIE NO:OU04011
 - 3) PRIMARY DIMENSION: A;B;D
 - 4) 1PC/MAG SLIP BAG+LABEL(B)
10PCS/PE BAG+LABEL(A)
 - 5) RoHS COMPLIANT

4	OUTER JACKET PVC 45Pa BEIGE(2209) (RoHS)
3	USB 2.0 A TYPE 4P FEMALE WHITE SOLDER TYPE (RoHS)
2	USB2.0 A/M WHITE SOLDER TYPE (RoHS)
1	UL2725 28#1P+26#2C+A+B(64%B, AM)+D OD:4.5MM BEIGE(2209) 1800MM (RoHS)

A	FIRST EDITION	23/06/08
REV.	ECR	DESCRIPTION	C.N. DATE
UNLESS OTHERWISE SPECIFIED: DIMENSIONS ARE IN MILLIMETERS ANGULAR TOLERANCE: ±1.0°		TITLE	
DIMENSIONS		TOLERANCE	
0.00 TO 30.00mm		±0.10mm	
30.01 TO 80.00mm		±0.13mm	
80.01 TO 150.00mm		±0.15mm	
150.01mm		±0.20mm	
MATERIAL		PART NO. 2111-2089	
FINISH		SCALE / SHEET 1/1 UNIT MM SIZE A4 REV. A	